

Set with hand dryer, soap dispenser and tap

- Countertop set with hand dryer, soap dispenser and tap with electronic sensor.
- Anodized forged aluminum set, silver finish. Also available in titanium finish (NOFER 01902.T), black finish (NOFER 01902.BK), gold finish (NOFER 01902.GD), polish finish (NOFER 01902.B) and rose gold finish (NOFER 01902.RS).
- Timeless design adaptable to any type of decoration.
- Robust and safe to be built without sharp edges or other dangerous elements.
- Durability and resistance to corrosion.
- Suitable for collectivities and places of high frequency of use.
- In accordance with the European directives of electrical safety and electromagnetic compatibility (CE).

SUGGESTED TEXT FOR PRESCRIPTION

NOFER countertop set with hand dryer, soap dispenser and tap activated with electronic infrared sensor and adjustable sensitivity. Made in anodized forged aluminum, silver finish. Independent control module with ABS plastic housing. 1200 W, 220-240 V, 50 Hz. Universal hand dryer motor speed 32000 r.p.m. Faucet with NEOPEARL aerator of 1,89 l/min of flow. Soap dispenser with 1,2 liter tank and adjustable dosage. Modern design, robust and resistance to corrosion. Suitable for collectivities and places of high frequency of use. Tap/dispenser/hand dryer dimensions: 318,6 height x 230 width x 286 depth (mm). Dimensions control module: 307 height x 281,4 width x 210 depth (mm). Made by NOFER, S.L.

TECHNICAL DATA

DISPENSER / TAP	
BOX DIMENSIONS	
BOX WEIGHT	
TAP DIMENSIONS MODEL 'HIGH' (assembled)	318,6 X 230 X 286 mm
TAP DIMENSIONS MODEL 'LOW' (assembled)	188 X 230 X 263 mm
TAP WEIGHT MODEL 'HIGH'	2 Kg
TAP WEIGHT MODEL 'LOW'	1,8 Kg
INSTALLATION	ON COUNTER DESK (SINK)
SINK REQUIRED HOLE DIAMETER	Ø35 mm
MATERIALS	
Colon	Extruded 6063 T5 aluminium. Averaged thickness 5 mm
Wheel base	Brigh PC plastic. Averaged thickness 3 mm.
wheel cover	Forged 6063 T5 aluminium. Averaged thickness 2.5 mm
Water pipe	EPDM (food grade) covered with stainless steel mesh.
Fittings	Chrome plated CW508L (EN 1652) brass
FINISHINGS	
01901.B	Chrome plated according with EN248 standards
01901.S	Sandblasting. Natural anodized 18 microns thickness (ISO 15184 / ISO 9227/ ISO 1134)
01901.T	Sandblasting. Titanium anodized 20 microns thickness (ISO 15184 / ISO 9227/ ISO 1134)
01901.BK	Sandblasting. Black anodized 20 microns thickness (ISO 15184 / ISO 9227/ ISO 1134)
01901.GD	Sandblasting. Gold anodized 20 microns thickness (ISO 15184 / ISO 9227/ ISO 1134)
01901.RS	Sandblasting. Rosé anodized 20 microns thickness (ISO 15184 / ISO 9227/ ISO 1134)
ACTIVATION	INFRARED SENSORS. SENSIBILITY CAN BE REGULATED
SENSOR SENSIBILITY	FROM 1 TO 15 CM (FACTORY SETUP: 8 cm)
WATER FLOW (WITH SPRAY SLIM AREATOR)	1.89 l/m (3 Bar) - ENCLOSED ALTERNATIVE: 5 l/min (3 Bar)
AREATOR	NEOPEARL
NOISE LEVEL AT 2m	70 db



NOFER S.L.
 Avenida de la fama, 118
 08940 · Cornellà de Llobregat (Barcelona)
 Tel +34 934 742 423 · Fax +34 934 743 548
 nofer@nofer.com · www.nofer.com

Related Products



TECHNICAL DATA

CONTROL MODULE	
BOX DIMENSIONS	
BOX WEIGHT	
CONTROL MODULE DIMENSIONS	307 X 281,4 X 210 mm
CONTROL MODULE WEIGHT (WITHOUT SOAP)	3,8 Kg
INSTALLATION	WALL MOUNTED OR FLOOR STANDING USING 'SILENTBLOCKS' (+50 mm in total height)
SET UP PARAMETERS	
CHECKING PROGRAM	SENSOR OPERATION TEST
SOAP CIRCUIT PURGER PUSH BUTTON	INCLUDED
SOAP DOSAGE	FROM 0 TO 3 s. 0,1 s. STEPS
MAXIMUM HAND DRYER OPERATION TIME	FROM 0 A 30 s. 1 s. STEPS
MAXIMUM WATER SOLENOID VALVE OPERATION TIME	FROM 0 A 30 s. 1 s. STEPS
WATER TEMPERATURE REGULATION	WITH MIXER (INCLUDED)
SOAP AND WATER AUTOMATIC HYGIENE ACTIVATION	INCLUDED
COVER MATERIAL	ABS 3 mm AVERAGED THICKNESS
HAND DRYER BLOWER MATERIAL	ABS V0. 3 mm AVERAGED THICKNESS
NOMINAL INTENSITY	5,3 A
VOLTAGE	220 V – 240 V~
STAND BY' CONSUMTION	0,009 A
ELECTRICAL ISOLATION	CLASS II
PROTECTION INDEX AGAINTS WATER AND DUST	IP35
HAND DRYER (INCLUDED AT CONTROL MODULE)	
POWER	1200 W
ELECTRICAL PROTECTION	SAFETY THERMAL LIMITER
VALDAL PROOF AUTOMATIC SWICHT OFF	YES - MAXIMUM OPERATION TIME 30 s
MOTOR TYPE	UNIVERSAL
MOTOR SPEED	32000 r.p.m.
AIR TEMPERATURE	40°C at 10 cm
AIR SPEED	
AIR FLOW	1980 l/min
DRYING TIME	12 - 15 s.
SOAP DISPENSER (INCLUDED AT CONTROL MODULE)	
DOSAGE SYSTEM	PERISTALTIC PUMP
VOLTAGE	5 V
INTENSISTY	0,3 A
MATERIAL DEPOSIT	PC. TRANSLUCENT BLACK
DEPOSIT CAPACITY	1,2 liters
WATER SOLENOID VALVE (INCLUDED AT CONTROL MODULE)	
MAXIMUM OPERATION PRESSURE	8 BAR
MINIMUM OPERATION PRESSURE	0,5 BAR
RECOMENDED OPERATION PRESSURE	3 BAR
VOLTAGE	5 V
CERTIFICATIONS	
SGS-CE	

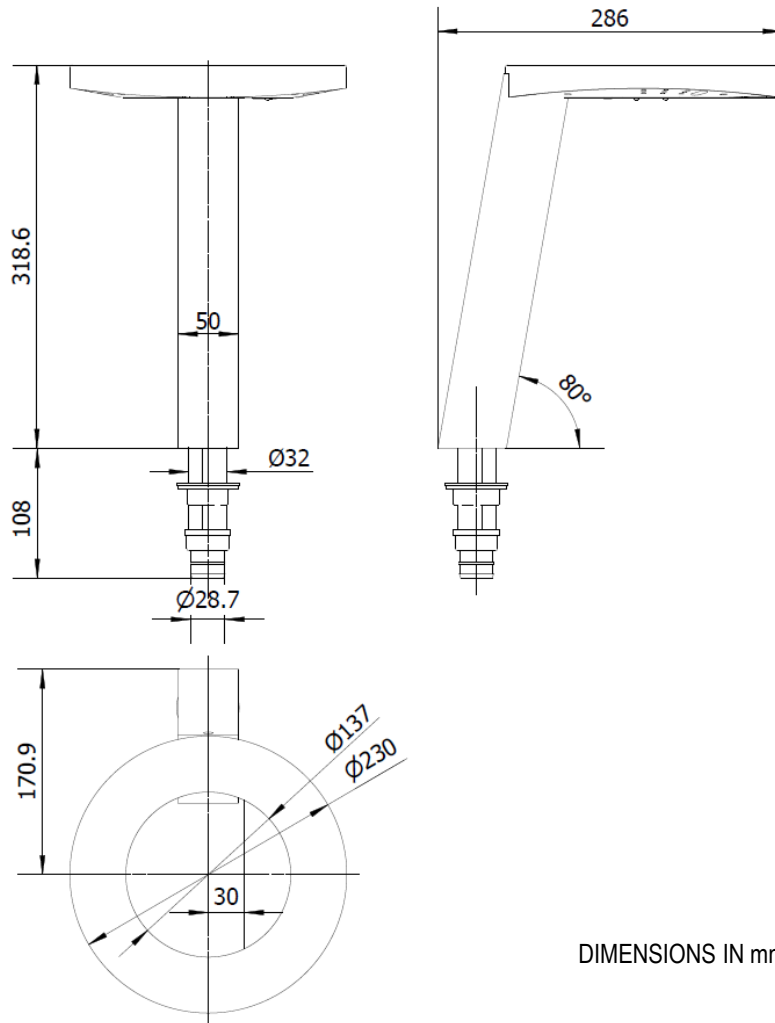

Set with hand dryer, soap dispenser and tap

TECHNICAL DRAWING



DIMENSIONS IN mm

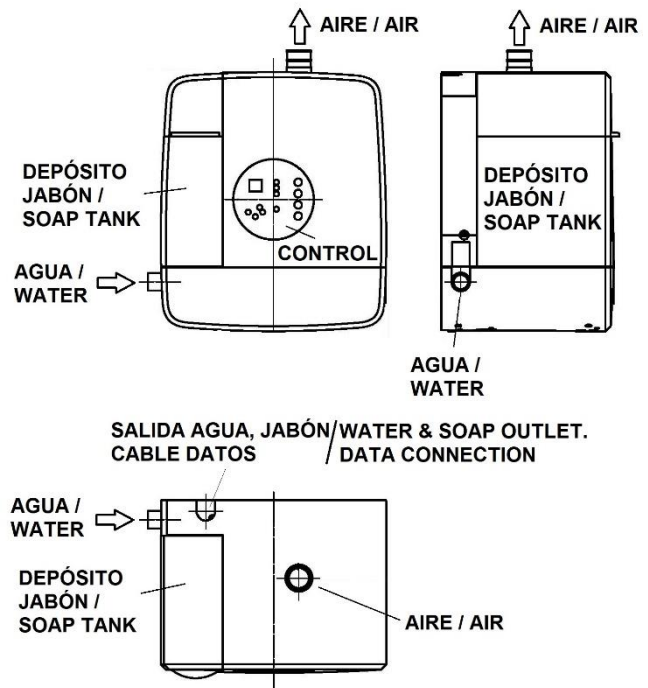
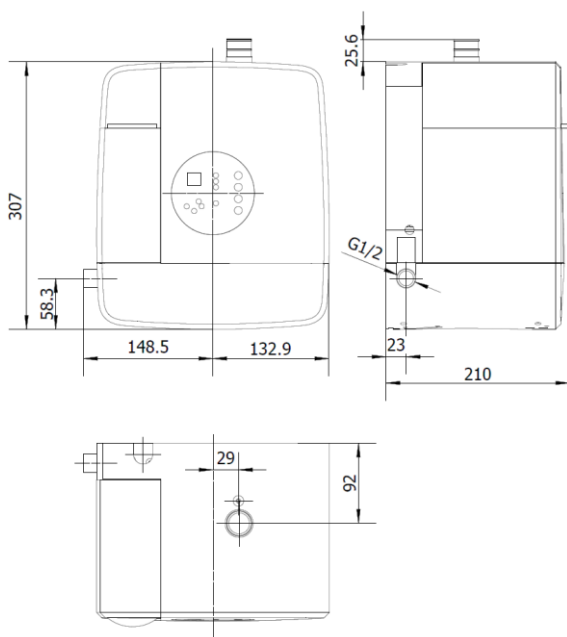

NOFER S.L.
 Avenida de la fama, 118
 08940 · Cornellà de Llobregat (Barcelona)
 Tel +34 934 742 423 · Fax +34 934 743 548
 nofer@nofer.com · www.nofer.com